



Operating Instructions for Digital Pressure Gauge

Model: MAN-SC/-LC



MAN-LC



MAN-SC



We don't accept warranty and liability claims neither upon this publication nor in case of improper treatment of the described products.

The document may contain technical inaccuracies and typographical errors. The content will be revised on a regular basis. These changes will be implemented in later versions. The described products can be improved and changed at any time without prior notice.

© **Copyright**
All rights reserved.

1. Contents

1. Contents.....	2
2. Note	4
2.1 General.....	4
2.2 Validity and version of the operating instructions.....	4
2.3 Hazard warnings.....	4
2.1 As per PED 2014/68/EU	5
2.2 Overview of the device functionality.....	5
3. Instrument Inspection.....	6
4. Regulation Use	6
5. Operating Principle.....	6
6. Mechanical Connection.....	7
6.1 Installation:.....	7
6.2 Orientation of the electronics housing.....	8
7. Electrical Connection	9
7.1 Inserting or changing the battery at MAN-SC	9
7.2 Electrical connection with MAN-LC.....	9
8. Layout of the LC display.....	10
9. Button function	11
9.1 Menu operation.....	12
10. Menu function – menu levels	13
10.1 Menu levels.....	13
11. Power management (MAN-SC).....	14
11.1 Display of the battery status.....	14
11.2 Sleeping mode.....	15
12. Display orientation.....	16
13. Display functions.....	18
13.1 Display overflow.....	18
13.2 Measurement value display resolution.....	19
13.3 Measuring overrange.....	19
13.4 MIN / MAX memory function	19
13.5 Force reading.....	20
14. Electrical outputs (only MAN-LC).....	20
14.1 Display of the output configuration.....	20

15. IO-Link function (only MAN-LC)	21
15.1 Specification	22
16. Device parameterization	23
16.1 Parameter table MAN-LC	23
16.2 Parameter table MAN-SC	27
16.3 Process of device parameterization	28
16.4 Display (main menu DISP)	28
16.5 Other (main menu MISC).....	29
16.6 Measurement (main menu MEAS)	29
16.7 Outputs (main menu OUT1, OUT2, only MAN-LC).....	31
16.8 User service (main menu USER).....	38
16.9 Factory service (main menu FACT).....	38
16.10 Info (main menu INFO).....	38
17. Maintenance	39
18. Technical Data	39
19. Device delivery status	39
20. Order codes	39
21. Dimensions	39
22. Disposal	40
23. IO-Link Process Data Structure	41
24. IO-Link manufacturer's declaration	42
24.1 MAN-LC Device-ID 196864	42
24.1 IO-Link Herstellererklärung für Device-ID 196865	43
24.2 IO-Link Herstellererklärung für Device-ID 196866	43
25. EU Declaration of Conformity.....	44
26. UK Declaration of Conformity.....	45

Manufactured and sold by:

Kobold Messring GmbH
Nordring 22-24
65719 Hofheim
Tel.: +49(0)6192-2990
Fax: +49(0)6192-23398
E-Mail: info.de@kobold.com
Internet: www.kobold.com

2. Note

2.1 General

Before unpacking and commissioning the device, the operating instructions and the “General Safety Instructions” document must be read and followed carefully. The general safety instructions, the operating instructions, the data sheet as well as approvals and further information can be downloaded via the QR code on the device or under the respective product on www.kobold.com.

Operating instructions, data sheet, approvals and further information via the QR code on the device or via www.kobold.com

The devices are only to be used, maintained and serviced by persons familiar with these operating instructions and in accordance with local regulations applying to Health & Safety and prevention of accidents.



When used in machines, the device should be used only when the entire machine fulfils the EU machinery directive.





2.2 Validity and version of the operating instructions

Due to technical changes, the device documentation available online may not always correspond to the product version you have purchased. If you need an instruction manual that corresponds to the purchased product version, you can request it from us free of charge by email (info.de@kobold.com) in PDF format, specifying the relevant invoice number and serial number. If you wish, the operating instructions can also be sent to you by post in paper form.

2.3 Hazard warnings

The following instructions are intended to ensure your personal safety and to prevent damage to the product described or connected devices. Safety instructions and warnings to prevent danger to the life and health of users or maintenance personnel, or to prevent damage to property, are highlighted in this documentation using the symbols defined here. *The symbols and terms used have the following meaning in the documentation itself:*

Symbol	Explanation	Symbol	Explanation
 Note	Is important information about the product, the handling of the product or the respective part of the documentation to which particular attention should be drawn.	 Caution	Means that minor personal injury or minor property damage may occur if proper precautions are not taken.

Symbol	Explanation	Symbol	Explanation
 Warning	Indicates that serious personal injury or substantial property damage may occur if proper precautions are not taken.	 Danger	Means that death can occur if proper precautions are not taken.
 Warning	Attention: Hot surface!	 Warning	Warning: Dangerous electrical voltage

2.1 As per PED 2014/68/EU

"Pressure gauges with a volume ≤ 0.1 L"

In acc. with Article 4 Paragraph (3), "Sound Engineering Practice", of the PED 2014/68/EU no CE mark.

Diagram 2

Vessels referred to in Article 4(1)(a)(i), second indent

2.2 Overview of the device functionality

 NOTE	Depending on the device firmware installed, the MAN-xC device can have a different range of functions. The differences in functionality can be found in the table below.
Note	

Software Revision	Functionality	Temperature measurement	IO-Link Device-ID (only MAN-xC)
Up to REV210901		No	196864 (decimal)
From REV221005		Yes (up to measuring range 700 bar)	196865 (decimal)
		No (measuring range > 700 bar)	196866 (decimal)
From REV241030	additional CUTOFF function for pressure and force measurement	Yes (up to measuring range 700 bar)	196865 (decimal)
		No (measuring range > 700 bar)	196866 (decimal)

3. Instrument Inspection

Instruments are inspected before shipping and sent out in perfect condition. Should damage to a device be visible, we recommend a thorough inspection of the delivery packaging. In case of damage, please inform your parcel service / forwarding agent immediately, since they are responsible for damages during transit.

Scope of delivery:

The standard delivery includes:

- Digital Pressure Gauge model: MAN-SC/-LC
- MAN-SC only: 9 V block battery (IEC 6 LR 61)

4. Regulation Use

Any use of the device, which exceeds the manufacturer's specification, may invalidate its warranty. Therefore, any resulting damage is not the responsibility of the manufacturer. The user assumes all risk for such usage.

5. Operating Principle

The devices of the type MAN-SC / -LC are used for measuring, monitoring and remote transmission of pressure-dependent operating processes in machines and systems.

The devices are equipped as follows:

- 5-digit LCD display
- Three programming buttons
- Process connection made of stainless steel
- Peak value memory
- Analog output, frequency output, switching output (MAN-LC)
- IO-Link function (MAN-LC)
- for MAN-SC: power supply via 9 V block battery
- for MAN-LC: external power supply via 24 VDC

The pressure to be measured is recorded by a ceramic sensor (>700 bar metal cell) and displayed via the electronics. At the same time, two electrical outputs are available at which various output functions can be parameterized (MAN-LC). In addition, the medium temperature is recorded and displayed using a sensor integrated into the measuring cell (not for measuring ranges over 700 bar).

6. Mechanical Connection

Before installation:

- Make sure that the maximum pressure in your system is within the measuring range of the digital manometer. The measuring range can be read on the nameplate.
- Make sure that the maximum permissible operating temperatures of the device are not exceeded.
- Make sure that there are no more packaging parts in the device.

6.1 Installation:

- Make sure that the pressure line is depressurized.
- The digital manometer is mounted like a mechanical manometer.
- The standard thread connection is sealed with a suitable seal (flat seal or sealing ring according to DIN 16258).
- When screwing in the device, don't screw in the housing, but on the hexagon (SW 24). Only use open-ended spanners for assembly!
- If possible, check after the mechanical installation whether the connection screw connection / pipe is tight.

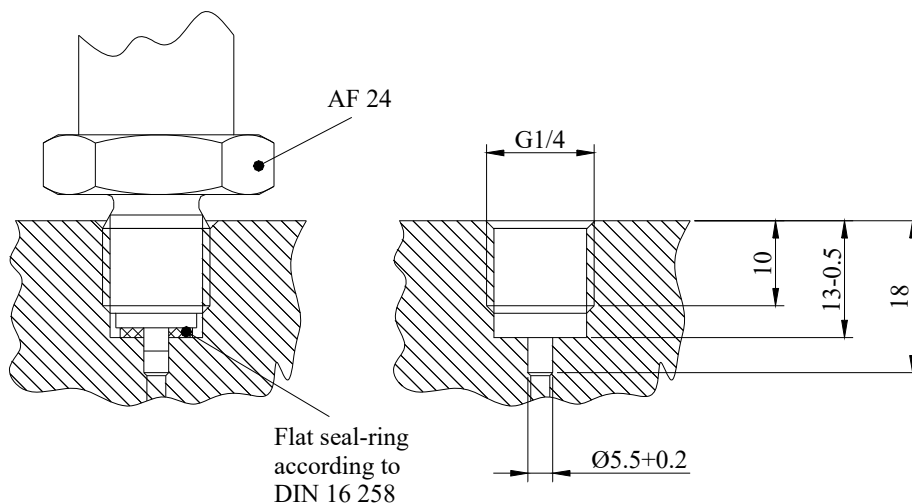

<p>NOTE</p> 	<p>After each mechanical installation of the sensor, a zero-point adjustment is required. (Menu item MISC / OFFSET, not for instruments with absolute pressure sensor). It is possible that the device will display a value other than 0 after disassembly, which can be corrected by adjusting the zero point before the next use. This is usually due to the changing ambient pressure. Adjusting the zero point is simply a snapshot of the pressure currently present.</p>
<p>Note</p>	

6.2 Orientation of the electronics housing



The electronics housing can be rotated by max. 180 ° in both directions. For this purpose, the lock nut must be released above the sensor housing, to rotate the electronics, and attract the locknut again. Attention: a greater rotation than 180 ° in one direction leads to tearing the sensor connection lines and destroys the device.

7. Electrical Connection

 Warning	Attention! Incorrect wiring will lead to damage of the unit's electronics.
--	--

7.1 Inserting or changing the battery at MAN-SC

To insert or replace the battery, the rear cover of the MAN-SC must be turned 1/4 turn to the left in order to open the bayonet lock. The cover can then be removed from the rear and the battery compartment is accessible. The new battery must be correctly attached to the existing battery clip according to the contacts. The battery must be placed in the battery compartment. Before closing the cover, make sure that the O-ring seal is correctly seated in the corresponding groove in the cover. The rear cover must be hand-tight to close so that it does not loose on vibration on the device.

7.2 Electrical connection with MAN-LC

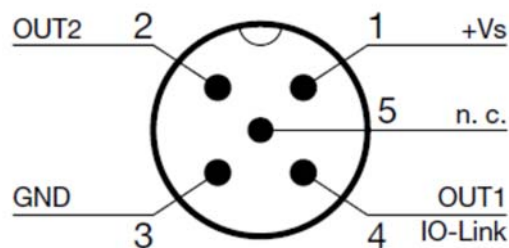
Connection	MAN-LC30
	
Supply voltage +Vs	M12x1 PIN 1
Supply voltage GND	M12x1 PIN 3
Output 1	M12x1 PIN 4
Output 2	M12x1 PIN 2
Not used	M12x1 PIN 5

8. Layout of the LC display

MAN-SC

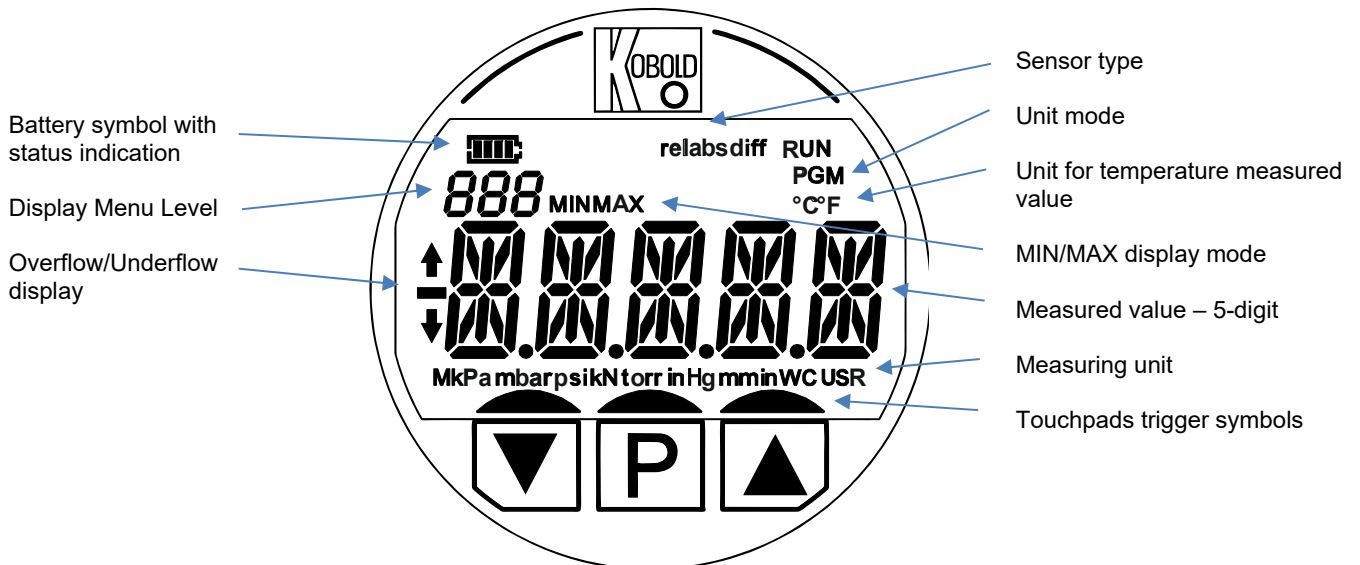

MAN-LC

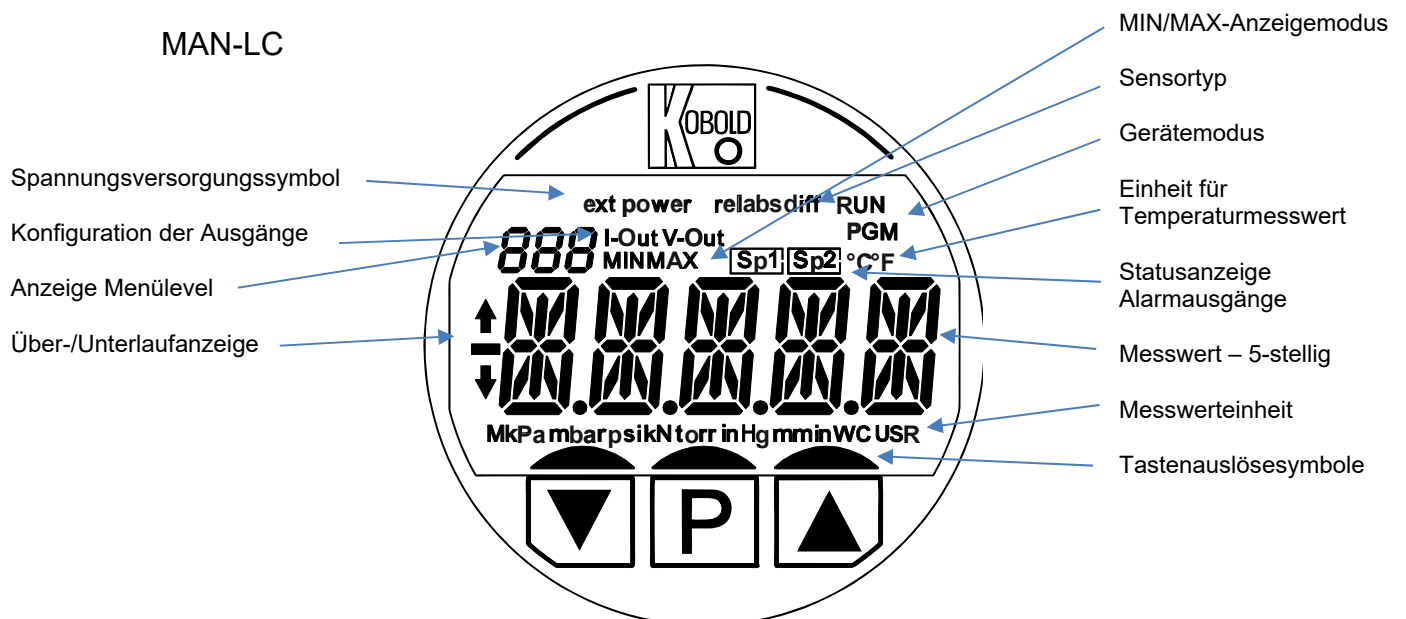

9. Button function

The 3 capacitive buttons below the display section are operated by placing your finger directly on the display panel. The active key areas are shown by the boundary lines.

The button functions are optimized for finger operation, operation with gloves is not possible. Adhering or standing drops of water on the keypads can interfere with the key function.

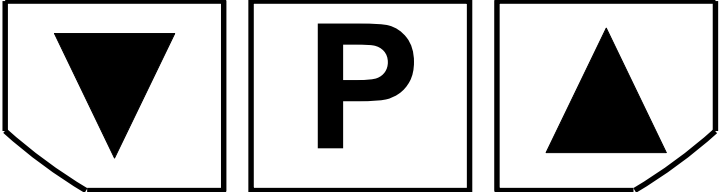
Operating condition	Key stroke			
Measuring function (RUN display)	Long	Display of MIN measured values	Call up menu function	Display of MAX measured values
Menu function (PGM display)	Short	Select value downwards (DOWN)	Confirm / save selection	Select value upwards (UP)
	Long	x	Back one menu level / exit the menu function	x

After each recognizable triggering of a key function, the finger must be lifted from the key surface in order to be able to trigger another key function (long or short).

The P key can be used to navigate in the settings menu: Short button press: Confirm selection or call up a submenu Long press: Leave the current menu level and switch to the higher-level menu level

9.1 Menu operation

Menu operation

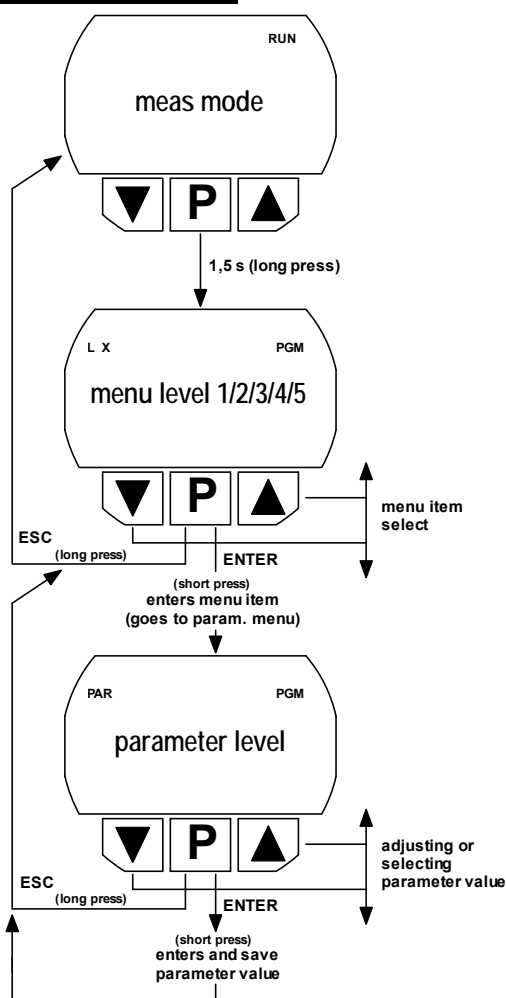

Menu level - value adjuster

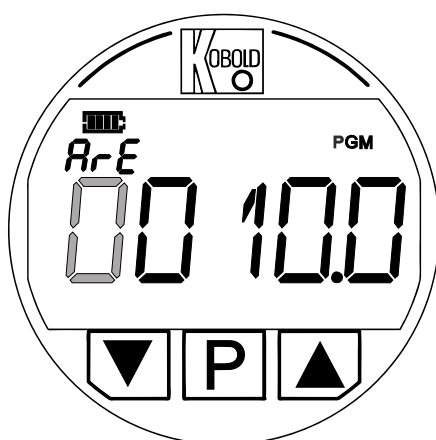

In the parameter level, the parameters are set either via a list selection or directly via a value adjuster.

The number of decimal places is fixed for each parameter with a value adjuster.

If the value adjuster is called up, the left adjustable digit flashes first. The numerical value can be changed with the UP or DOWN button. The next right digit can be set by briefly pressing the P key. The adjustable position can be moved to the left again by pressing and holding the P button.

If the last digit on the right is set (for many parameters up to 3 decimal places), the parameter value is saved by confirming with the P key and the value adjuster is exited.

For parameters with more than 5 adjustable locations, the display section is shifted to the right by selecting the adjustable location by a location to the right until the smallest adjustable location is displayed.

10. Menu function – menu levels

10.1 Menu levels



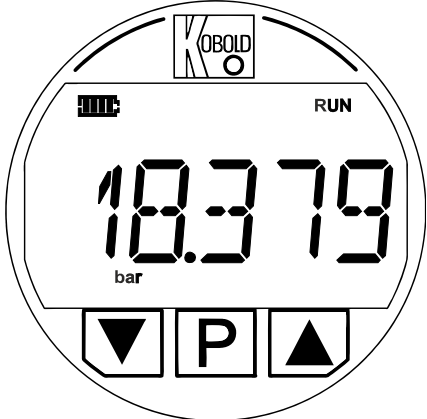
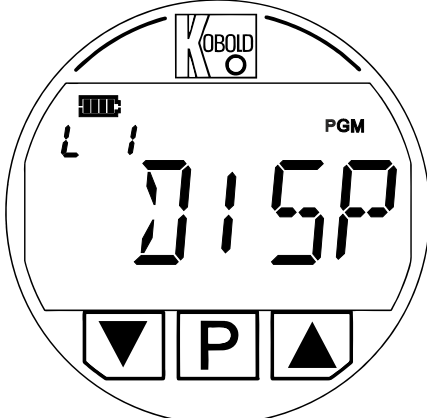
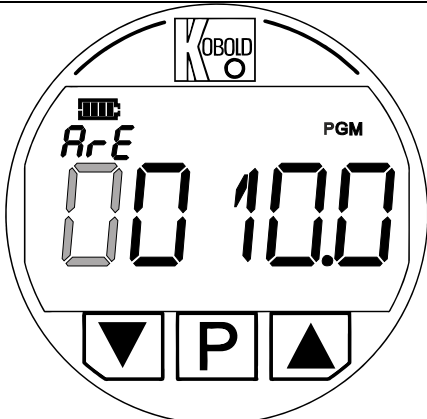

If the P key is pressed for longer than 3 seconds, the device changes from measuring mode (RUN display symbol) to menu mode (PGM display symbol).

	<p>Measuring mode</p>
	<p>Menu level Level 1 - 5</p>
	<p>Parameter level (List selection or value entry)</p>

11. Power management (MAN-SC)

11.1 Display of the battery status

The battery life used is indicated by the number of segments in the battery symbol. Depending on the type of battery used and the ambient temperature, the display can be inaccurate or fluctuate by 1 segment. The battery status display is matched to the discharge characteristics of alkaline battery types.

Symbol	Status	Note
	$\geq 80 \%$	-
	$\geq 60 \%$... $< 80 \%$	-
	$\geq 40 \%$... $< 60 \%$	-
	$\geq 20 \%$... $< 40 \%$	-
	$< 20 \%$	Change the battery if necessary!

11.2 Sleeping mode

For the purpose of maximizing the service life of the battery, automatic sleep mode activation can be set in the device, which puts the device into sleep mode after an adjustable time without pressing a button. If sleep mode is active, the device can be woken up again at any time by pressing a button. There are 3 different sleep modes available, which lead to different energy savings and serve different purposes.

Setting parameters in the menu: DISP / SLEEP or DISP / TOFF

Sleep mode	Description	Power consumption *	Note
-	-	~ 55 μ A	Normal measuring mode, parameter TOFF = 0
0	Display is switched off	~ 45 μ A	Low power savings through display switch-off, measurement continues
1	The display is switched off and the measurement is stopped	~ 20 μ A	Fast operational readiness after waking up (1 to 2 s)
2	Device in deepest sleep mode. No measuring function	~ 13 μ A	Device restarts after waking up. Operational readiness after approx. 5 s. Suitable for storage of devices with inserted battery

*: Average power consumption from a 9V battery

12. Display orientation

The electronic unit of the MAN-SC / MAN-LC can be rotated by the user in 90 ° steps in order to adapt the display direction to the installation position:

- Unscrew the display screw ring
- Carefully remove the electronics unit from the electronics housing (note the limited cable length of the sensor and M12x1 connector!)
- Turn the electronics unit and reinsert it in the specified locking position
- Screw on the screw ring again (tightening torque max. 3 Nm)

Attention: The electronics unit may be rotated by a maximum of 180 ° in one direction, otherwise there is a risk that the connecting wires will be torn out of the terminals!

The electronics module is connected to the sensor and connector or battery clip as follows:

MAN-SC without temperature sensor

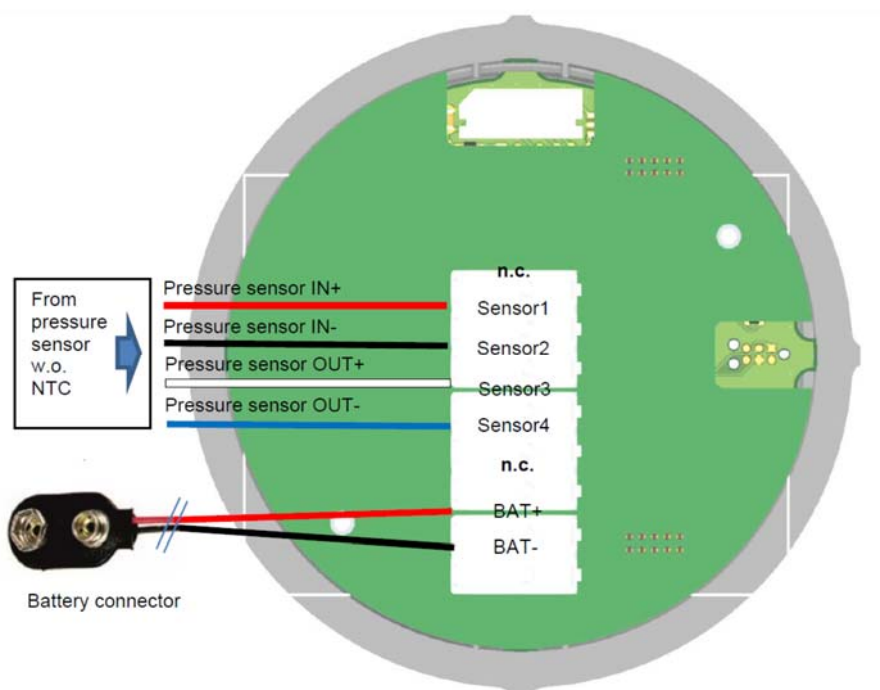

MAN-SC with temperature sensor

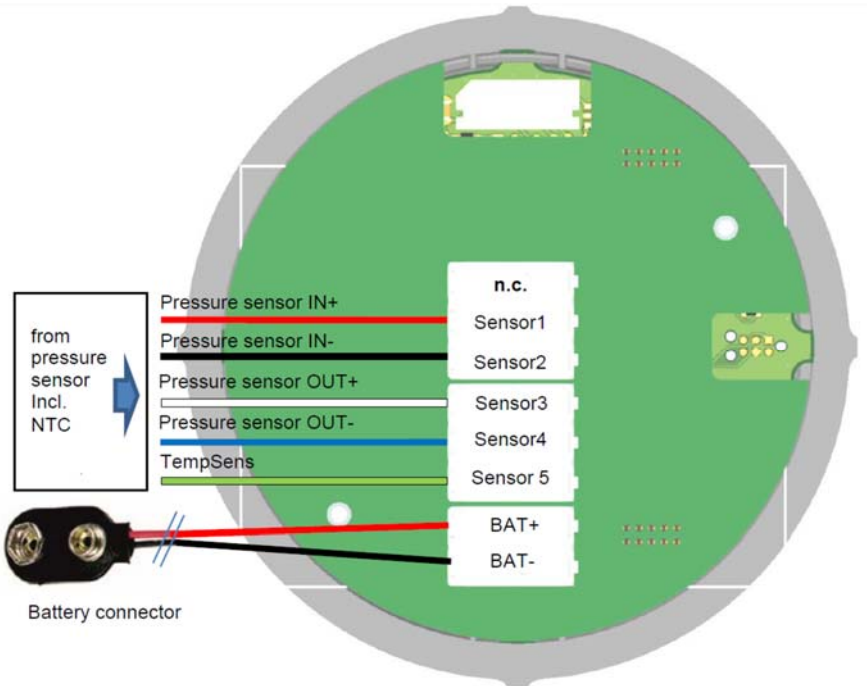

MAN-LC without temperature sensor

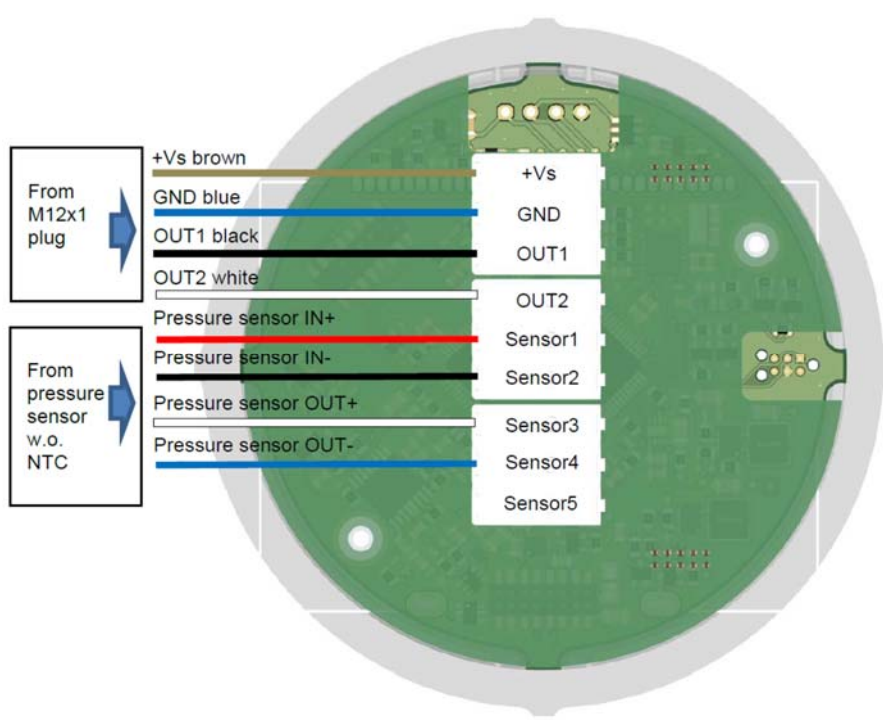

MAN-LC with temperature sensor

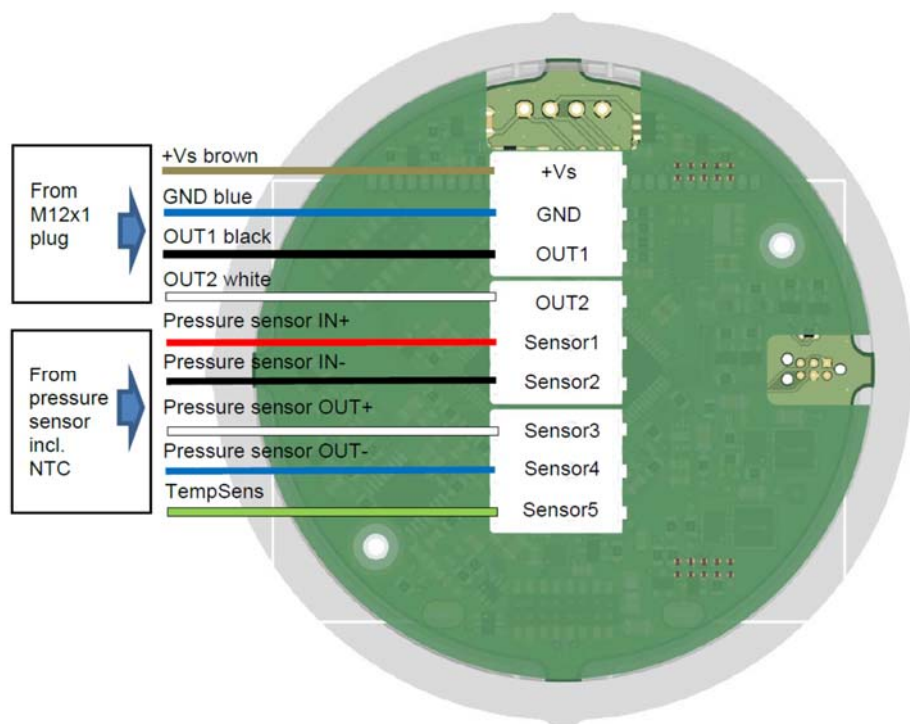

13. Display functions

13.1 Display overflow

The measured value display has a display area of +/- 99999 (5 digits). The display of the measured values is always 5-digit, whereby the number of pre-decimal places defines the number of decimal places displayed: pre-decimal places + decimal places = 5 The max. Number of decimal places is limited to 4.

Pre-decimal position [V]	Decimal positions [N]	Display
0	4	0,NNNN
1	4	V,NNNN
2	3	VV,NNN
3	2	VVV,NN
4	1	VVVV,N
5	0	VVVVV

If the measured value exceeds 5 pre-decimal positions, the display shows 5 strokes in the display for displaying the display overflow (- - - -). This may occur if e.g. the display unit of a measured value is changed to a small unit. Accordingly, the display overflow can be prevented or remedied when a larger display unit is selected.

13.2 Measurement value display resolution

The measured values for pressure and force are always displayed with 5 digits. Depending on the size of the measured values, the display is rounded, with the last or the last two display digits being calmed down and therefore not changing. The display resolution of the measured values is, however, always greater than the specified measuring accuracy of the device, despite rounding.

13.3 Measuring overrange

If the measured value exceeds the final value of the measuring range by more than 5% of the measuring range span, the overflow symbol (↑) is shown on the display to the left of the measured value. In the same way, the underflow symbol (↓) is displayed as long as the measured value is at least 5% of the measuring range span below the measuring range start value.

Status	Condition
Overflow (↑)	Measured value > MBE + (MBA - MBE)*0.05
Underflow (↓)	Measured value < MBA - (MBA - MBE)*0.05

13.4 MIN / MAX memory function

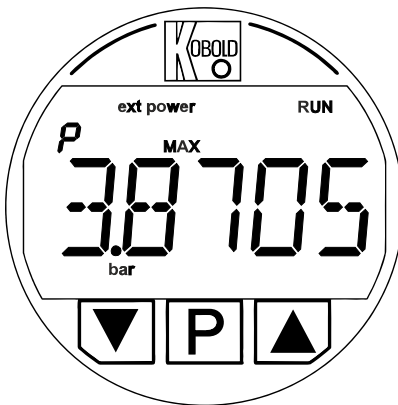

The MAN-SC / -LC devices have a peak value storage function as standard. For both measured values pressure and force, the minimum and maximum measured value is continuously recorded and saved. The respective MIN or MAX values are displayed by pressing and holding the UP or DOWN key in the measuring mode.

Measuring mode	
MIN display function	MAX display function
▼	▲
Reset MIN / MAX memory	
P	



If the MIN or MAX display function is activated, the corresponding values for pressure and force are displayed alternately for 5 seconds each. During this time, the corresponding memory can be reset to the current measured value by pressing the P key for a longer period of time.

After switching off the supply voltage or changing the battery, the MIN / MAX values are retained in the internal memory.

13.5 Force reading

Calculation of the force measurement value F

The measured value for force is converted using the pressure measured value and a reference surface (AREA parameter):

$$Force [N] = 10 \times AREA \times measured\ pressure\ value$$

with $AREA = reference\ area\ in\ [mm^2]$
 and $pressure\ measured\ value\ in\ [bar]$

14. Electrical outputs (only MAN-LC)

14.1 Display of the output configuration

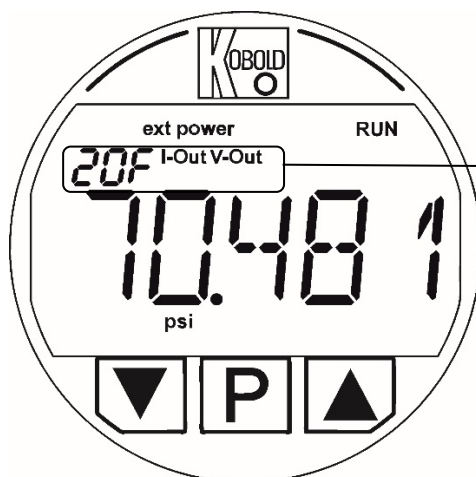

In measuring mode, the configuration of the electrical outputs for output 1 and output 2 is shown alternately in the small 3-digit 7-segment display on the MAN-LC. The display coding can be found in the table.

If output 2 is configured as a current output, the "I-OUT" symbol is permanently displayed, if output 2 is configured as a voltage output, the "V-OUT" symbol is permanently displayed.

Digit 1 Exit no.	Digit 2 Output type 1	Digit 3 Output type 2	Function
1	0	F	Output 1 deactivated
1	I	0	Output 1 IO-Link (factory setting)
1	_	F	Output 1 frequency output
1	S	P	Output 1 switching output
1	K	0	Output 1 KofiCom (only for factory settings)
1	_	C	Output 1 control input
2	0	F	Output 2 deactivated (factory setting)
2	A	4	Output 2 4-20mA
2	A	0	Output 2 0-20mA
2	V	0	Output 2 0-10VDC
2	V	2	Output 2 2-10VDC
2	_	F	Output 2 frequency output
2	S	P	Output 2 switching output

15. IO-Link function (only MAN-LC)

The MAN-LC pressure sensor has an IO-Link communication interface as standard. Process and diagnostic data can be accessed directly via this interface and the device can be parameterized.

The setup menu remains locked when the IOLINK mode is active and is inaccessible.

To ensure that the IO-Link device can be operated correctly on the connected IO-Link master, it is necessary to install the device description file matching the device.

The device description files (IODD) are available in the IODDfinder database under ioddfinder.io-link.com. There may be different IODD versions available for devices of the same type. To select the correct IODD, the device ID can either be read out via the connected IO-Link master or, alternatively, identification can be made using the device's firmware identifier.

Appendix IO-Link specification MAN-LC

The specifications and parameters for the MAN-LC devices with IO-Link function are available on the website <https://ioddfinder.io-link.com>. Here you will find the necessary information for:

- Process data structure
- Diagnostic functions
- IO-Link commands
- ISDU parameters

The following table provides links to the 3 different versions.

Software Version	Measuring range	Temperature measuring	Device-ID (dezimal)	Link
Up to REV210901	All	No	196864	https://ioddfinder.io-link.com/productvariants/search/32641
From REV221005	Up to 700 bar	Yes	196865	https://ioddfinder.io-link.com/productvariants/search/45601
	greater than 700 bar	No	196866	https://ioddfinder.io-link.com/productvariants/search/45602

* In this version without temperature measurement, the process value for temperature is permanently output at -128 °C.

How to download the correct IODD:

- Read out the firmware ID of the device from the INFO menu
- Find out the device ID (decimal) from the table above according to the firmware identification and the product type
- In the IODD finder, identify the correct IODD using the Device ID column and download the associated ZIP file using the download button.

If the device is operated on an IO-Link master with port class A, only a maximum output current of 50 mA may be drawn from output 2 (OUT2) (current or binary output), otherwise the IO-Link master will be overloaded and it can cause malfunctions.

 <p>Note</p>	<p>If a measured value is invalid due to an error status (NAN), the corresponding process value is output with the value "0". In this case, the device status and the events must also be taken into account.</p>
---	---

15.1 Specification

Manufacturer	ID 1105 (decimal), 0x0451 (hex)
Manufacturer name	Kobold Messring GmbH
IO-Link specification	V1.1
Bitrate	COM2
Minimum cycle time	10 ms
SIO mode	yes (OUT1 in configuration IO-Link)
Block parameterisation	yes
Ready for operation	10 sec.
Max. cable length	20 m
IO-Link master port class	A

16. Device parameterization

16.1 Parameter table MAN-LC

Menu level					Description	Parameter value range	Factory setting	
Level 1	Level 2	Level 3	Level 4	Level 5				
Abbreviations: P = pressure reading T = temperature reading F = force measurement value								
DISP	REFRE				Display refresh rate	1 - 10 s	1.3 s	
	LAY	SING			Permanently shows the measured value configured under DISPV / FIRST	-	SING	
		ALTE			Alternately displays the two measured values configured under DISPV	-		
	DISPV	FIRST			Measured value for first display	P, T, F	P	
		SECON			Measured value for second display	P, T, F	F	
	M OUT				If the value > 0, the setting menu is exited automatically after [VALUE] s	0 - 60 s (0 = Off)	0	
MISC	OFFSET**				If YES is confirmed, sets the current pressure measurement value as the zero point (duration of the calibration function: 5 sec.)	NO / YES	NO	
	AREA				Reference area in [mm ²] with which the measured pressure value P is converted into the measured force value F.	0 – 9999,9	10,0	
MEAS	0: P 1: T 2: F	UNIT			Measurement unit, selection via display symbols USR = user unit Input value P = [USR] / [bar] Input value F = [USR] / [N] Input value T = [USR]/[°C]/[°F]	P: bar/mbar/Pa/kPa/MPa/psi/torr/ inchHg/mmWC/ inchWC/USR F: N/kN/USR T: °C/°F	P: according to the table "Cutoff values", see datasheet F: N T = °C	
		CUTOF			Sets a measurement range bidirectionally around the zero point in which all measurement values are set to "0" and thus suppressed. Not available for the temperature measurement value.	0 – Measuring range end	according to the table "Cutoff values", see datasheet	
		SIM	ACT*			Simulation activation Simulation switches off after SIM auto-stop time (see USER menu)	DIABL / ENABL	DIABL
			MODE	STATI		Constant value	STATI / TRIAN / MONO	STATI
				TRIAN		Value progression in triangular form		
				MONO		Monotonically increasing value		
		S VAL		Start value for MONO and TRIAN		MBA ... MBE [Unit]	0,00	
I VAL		Interval increment (not for STATI mode)		MBA ... MBE [Unit]	1			

MAN-SC/-LC

Menu level					Description	Parameter value range	Factory setting		
Level 1	Level 2	Level 3	Level 4	Level 5					
Abbreviations: P = pressure reading T = temperature reading F = force measurement value									
			INTER		Number of intervals (not for STATI mode)	0 - 65000	20		
			TIME		Time between intervals (not for STATI mode)	0 - 50000 [ms]	50 ms		
OUT1	0: P 1 = T 2: F	DISAB			Output deactivated				
		ALARM	FUNC	LIMIT	Limit value function	LIMIT / WINDO	WINDO		
				WINDO	Window function				
		TYPE			Physical output type: NPN = negative switching, PNP = positive switching, PP = switching on both sides (PushPull)	NPN / PNP /PP	PP		
		SWIT			Logical output function NO = normally open function, NC = normally closed function	NO / NC	NO		
		THRE			Switching threshold	MBA - MBE [Unit]	MBE		
		LTHRE			Lower switching threshold (only with activated window function)	MBA - MBE [Unit]	40		
		HYST			Hysteresis	MBA - MBE [Unit]	0		
		SUPPR			Switching delay factor (x100ms)	0 - 60	0		
		SU DI			Switching delay direction up / down / both sides	UP/DOWN/ BOTH	UP		
		FREQ	MAXF			Output frequency for measured value MAXHZ	0 - 1000 [Hz]	500	
			OVERF			Overflow in% of MAXF	0 - 100 [%]	1	
			0HZ			Measured value at which 0 Hz is output	MBA - [MAXF] [Unit]	0,00	
			MAXHZ			Measured value at which MAXF is output	[0HZ] - MBE [Unit]	MBE	
		KOFIC			KofiCom communication mode	-	-		
		IOLIK			IO-Link communication mode	-	-		
		CTLIN	FUNC			Function control input Off / MIN-MAX memory reset	OFF / M RST	OFF	
		OUT2	0: P 1 = T 2: F	DISAB			Output deactivated		
				ALARM	FUNC	LIMIT	Limit value function	LIMIT / WINDO	WINDO
						WINDO	Window function		
TYPE				Physical output type: NPN = negative switching, PNP = positive switching, PP = switching on both sides	NPN / PNP /PP	PP			
SWIT				Logical output function NO = normally open function, NC = normally closed function	NO / NC	NO			

Menu level					Description	Parameter value range	Factory setting
Level 1	Level 2	Level 3	Level 4	Level 5			
Abbreviations: P = pressure reading T = temperature reading F = force measurement value							
			THRE		Switching threshold	MBA - MBE [Unit]	MBE
			HYST		Hysteresis	MBA - MBE [Unit]	0
			SUPPR		Switching delay factor (x100ms)	0 - 60	0
			SU DI		Switching delay direction up / down / both sides	UP/DOWN/ BOTH	UP
		4-20	NAMUR		Activates output overflow and underflow behavior according to NAMUR	ENABL / DIAB	ENABL
			4MA		Measurement value for 4mA output current (20MA value must be greater than 4MA value)	MBA - [20MA] [Unit]	MBA
			20MA		Measured value for 20mA output current (20MA value must be greater than 4MA value)	[4MA] - MBE [Unit]	MBE
		0-20	NAMUR		Output overflow and underflow behavior according to NAMUR	ENABL / DIAB	ENABL
			0MA		Measurement value for 0mA output current (20MA value must be greater than 0MA value)	MBA - [20MA] [Unit]	MBA
			20MA		Measured value for 20mA output current (20MA value must be greater than 0MA value)	[0MA] - MBE [Unit]	MBE
		2-10V	NAMUR		Output overflow and underflow behavior according to NAMUR	ENABL / DIAB	ENABL
			2V		Measured value for 2V output voltage (10V value must be greater than 2V value)	MBA - [10V] [Unit]	MBA
			10V		Measured value for 10VA output voltage (10V value must be greater than 2V value)	[2V] - MBE [Unit]	MBE
		0-10V	NAMUR		Output overflow and underflow behavior according to NAMUR	ENABL / DIAB	ENABL
			0V		Measured value for 0V output voltage (10V value must be greater than 0V value)	MBA - [10V] [Unit]	MBA
			10V		Measured value for 10VA output voltage (10V value must be greater than 0V value)	[0V] - MBE [Unit]	MBE
		FREQ	MAXF		Output frequency for measured value MAXHZ	0 - 1000 [Hz]	500
			OVERF		Overflow in % of MAXF	0 - 100 [%]	1
			0HZ		Measured value at which 0 Hz is output	MBA - [MAXF] [Unit]	0,00

MAN-SC/-LC

Menu level					Description	Parameter value range	Factory setting
Level 1	Level 2	Level 3	Level 4	Level 5			
			MAXHZ		Measured value at which MAXF is output	[0HZ] - MBE [Unit]	MBE
USER	PASSW				Defines the USER menu password (00000 = USER menu open)	00000 - 99999	00000
	FACRS				If YES resets all parameters to the factory setting	NO / YES	NO
	MLOCK				Activates the password query when entering the menu	ULOCK / LOCK	ULOCK
	SAS				Simulation of auto stop time. Specifies the time in minutes after which the simulation is automatically ended	1 - 31 min	10
FACT	PASSW				Factory settings menu, password protected (access only for service purposes)		
INFO	GEN				General device information	MAN-SC / MAN-LC	-
	VER				Firmware version	Vxx.xx	-
	REV				Firmware revision	##### (Release date)	-

* The ACT parameter must be set to ENABLED so that the other parameters are displayed

** The offset function is not available for devices with an absolute pressure sensor

16.2 Parameter table MAN-SC

Menu level					Description	Parameter value range	Factory setting
Level 1	Level 2	Level 3	Level 4	Level 5			
DISP	REFRE				Display refresh rate	1 - 10 s	1.3 s
	SLEEP				Sleep mode	0,1,2	0
	TOFF				TimeOut time	0 - 120 min.	0 (AUS)
	LAY	SING			Permanently shows the measured value configured under DISPV / FIRST	-	SING
		ALTE			Alternately displays the two measured values configured under DISPV	-	
	DISPV	FIRST			Measurement type for first display	P, T, F	P
		SECON			Measurement type for second display	P, T, F	F
M OUT				If the value > 0, the setting menu is exited automatically after [VALUE] s	0 - 60 s (0 = Aus)	0	
MISC	OFFSET**				If YES is confirmed, sets the current pressure measurement value as the zero point (duration of the calibration function: 5 sec.)	NO / YES	NO
	AREA				Reference area in [mm ²] with which the measured pressure value P is converted into the measured force value F.	0 – 9999,9	10,0
MEAS	0: P 2: F	UNIT			Measurement unit, selection via display symbols USR = user unit Input value P = [USR] / [bar] Input value F = [USR] / [N] Input value T = [°C]/[°F]	P: bar/mbar/Pa/ kPa/MPa/psi/torr/ inchHg/mmWC/ inchWC/USR F: N/kN/USR T: °C/°F	P: according to the table "Cutoff values", see datasheet F: N T: °C
		CUTOF			Sets a measurement range bidirectionally around the zero point in which all measurement values are set to "0" and thus suppressed. Not available for the temperature measurement value.	0 – Measuring range end	according to the table "Cutoff values", see datasheet
	SIM	ACT*			Simulation activation Simulation switches off after SIM auto-stop time (see USER menu)	DIABL / ENABL	DIABL
		MODE	STATI		Constant value	STATI / TRIAN / MONO	STATI
			TRIAN		Value progression in triangular form		
			MONO		Monotonically increasing value		
		S VAL		Start value for MONO and TRIAN		MBA ... MBE [Unit]	0,00
		I VAL		Interval increment (not for STATI mode)		MBA ... MBE [Unit]	1
INTER		Number of intervals (not for STATI mode)		0 - 65000	20		

Menu level					Description	Parameter value range	Factory setting
Level 1	Level 2	Level 3	Level 4	Level 5			
			TIME		Time between intervals (not for STATI mode)	0 - 50000 [ms]	50 ms
USER	PASSW				Defines the USER menu password (00000 = USER menu open)	00000 - 99999	00000
	FACRS				If YES resets all parameters to the factory setting	NO / YES	NO
	MLOCK				Activates the password query when entering the menu	ULOCK / LOCK	ULOCK
	SAS				Simulation of auto stop time. Specifies the time in minutes after which the simulation is automatically ended	1 - 31 min	10
FACT	PASSW				Factory settings menu, password protected (access only for service purposes)		
INFO	GEN				General device information	MAN-SC / MAN-LC	-
	VER				Firmware version	Vxx.xx	-
	REV				Firmware revision	##### (Release date)	-

* The ACT parameter must be set to ENABLED so that the other parameters are displayed

** The offset function is not available for devices with an absolute pressure sensor

16.3 Process of device parameterization

The MAN-SC / -LC pressure sensor is pre-parameterized at the factory. In the event of subsequent changes to pressure or force measurement units, the parameters that depend on this are converted and adjusted accordingly. The limit value parameters of the switching outputs must, however, be checked and adjusted by hand when adjusting pressure and force units - these are not automatically converted. An inadvertent change to the parameterization can be revised using the "Reset factory settings" function in the USER / FACRS menu.

16.4 Display (main menu DISP)

16.4.1 Refresh

The "Refresh" parameter defines the time interval within which the measurement variables are displayed. The "refresh rate" can be increased in steps from 1 s to 10 s. An increase in the refresh rate time causes an increased "filtering" of the display value.

16.4.2 Sleep mode (parameters SLEEP and TOFF, only MAN-SC)

See section 11.2

16.4.3 Display layout (LAY submenu)

Here you can select whether 1 measured value (SING) or 2 measured values (ALTE) are displayed alternately.

16.4.4 Display value (DISPV parameter)

With the help of this parameter, the measurement variables made available by the transducer can be displayed. Depending on the 'Layout' display, either one or two measurement variables can be displayed.

16.4.5 Menu timeout (parameter M_OUT)

The menu timeout time defines the time after which the menu function is automatically exited without a key being pressed. With the setting "0 s" this function is deactivated and the menu function can only be exited manually by pressing the back button (several times).

16.5 Other (main menu MISC)

16.5.1 Zero point adjustment function (OFFSET parameter)

If YES is confirmed, sets the current pressure measurement value as zero point (duration of the calibration function: 5 sec.) This function is not available for devices with an absolute pressure measuring cell.

16.5.2 Reference surface force measured value (AREA parameter)

Reference area in [mm²] with which the measured pressure value P is converted into the measured force value F (see section 13.4)

16.6 Measurement (main menu MEAS)

The measurement variables provided by the transducer are listed under the "MEAS" menu. With the pressure sensor MAN-SC / -LC these are:

- Pressure measurement value (measurement variable 0, submenu "0: P"
- Force measurement value (measurement variable 2, submenu "2: F"
- Temperature measurement value (measurement variable 1, submenu "1:T")

Each measurement variable is still divided into its own submenu. In the submenu, all parameters relating to the respective measurement variables can be adjusted.

16.6.1 Pressure (submenu 0: _P)/temperature (submenu 2:_T)/force (submenu 2: _F)

16.6.2 Unit (UNIT parameter)

The displayed unit for the pressure measurement can be selected from various predefined standard units. The definition of a user-specific unit "USR" is also possible. The unit is selected by selecting the unit symbol in the display.

If the USR unit is selected, a factor for the basic unit "bar" must be entered. E.g. unit "USR" = 10 bar, then at 20 bar measured value 2.0 "USR" is shown on the display.

The unit "USR" can be set independently of one another for pressure, temperature and force measured values.

16.6.3 Simulation mode (submenu SIM)

With the simulation function, all available measured values can be simulated independently of one another for a limited period of time. The simulated measured values have a full effect on the displays and outputs.

Each simulation started is automatically ended after the time set in the "Sim Autostop Time" (user service) parameter (1 to 30 minutes) or after the programmed intervals have elapsed.

The following measured values can be simulated:

Pressure and force

Note: If a simulation is carried out for the measured value pressure, the measured value for the force remains unaffected. The dependency of the force measured value on the pressure measured value is omitted in the simulation.

The simulation starts as soon as the simulation is activated and the setting menu is exited. The simulation is interrupted or stopped if the settings menu is called up in the meantime. There are 3 different types of simulation available for each purpose:

a.) "Static" mode

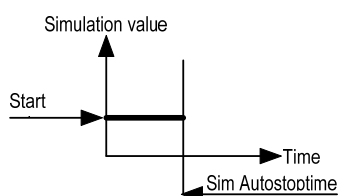

In the "Static" mode, a constant value is output for the measured values pressure and force. The simulation ends after the set simulation time.

b.) „Triangle“ mode

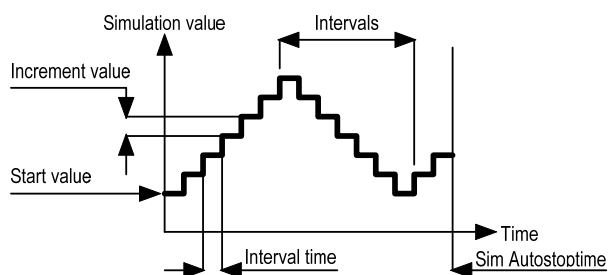

In "Triangle" mode, the simulation value increases continuously in the increment of the parameter "Increment value" and in the interval "Interval time" with the "Start value". After the amount of the parameter "intervals", the simulation value decreases again in the same way, in order to increase again.

This process is repeated continuously until the set time "Sim Auto Stop Time" has expired and the simulation ends.

c.) "Monotonic" mode

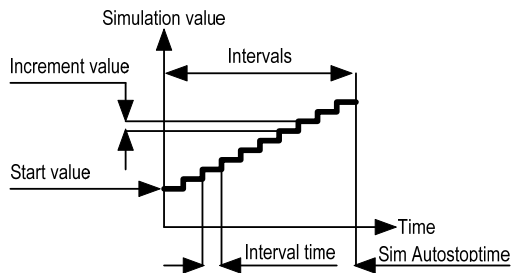

In "Monotonic" mode, the simulation value increases continuously in the step size of the parameter "Increment value" and in the interval "Interval time" with the "Start value". After the amount of "Intervals" or the expiration of "Sim Auto Stop Time", the simulation ends.

16.7 Outputs (main menu OUT1, OUT2, only MAN-LC)

The MAN-LC pressure measuring device provides a total of 2 outputs, most of which are freely configurable. The outputs (output 1 and output 2) are configured using a wizard function. The wizard function guides the user step by step through all the necessary settings.

Steps:

- Select output (select submenu OUT1 or OUT2)
- Selection of the source or the measurement variable to be output (pressure, temperature or force)
- Selection of an output type (4-20 mA, 0-20 mA, 0-10 V, 2-10 V, alarm, Frequency output, IO-Link, control input)
- Setting of the output (scaling, thresholds, function)
- Save the configuration

The different output types are optimized for different types of application. The following table contains the application recommendations for the various output types. If the outputs are not used according to the recommendations, measurement deviations may occur and the desired functionality will not be achieved.

Application	Output type		
	Analog output (all variations)	Frequency output	Alarm output
Remote transmission of measured values	✓	✓	
Limit value monitoring			✓
Window surveillance			✓

Configuration of the outputs MAN-LC ...

Output 1 (OUT1, PIN4)	Output 2 (OUT2, PIN 2)
	Analoge output 4-20 mA
	Analoge output 0-20 mA
	Analoge output 2-10 V
	Analoge output 0-10 V
Alarm output NPN/PNP/PP	Alarm output NPN/PNP/PP
Frequency output PP	Frequency output PP
KofiCom communication mode	
Communication mode IO-Link	
Control input	

16.7.1 Alarm output (OUT1 and OUT2)

The alarm outputs can be parameterized with a limit or a window function.

If the alarm function is activated for one or both outputs, the corresponding symbols Sp1 or Sp2 are shown in the display. If the measured value exceeds the set switching point (with limit function) or if the measured value is outside the defined window (window function), a rectangle is displayed around the respective symbol Sp1 or Sp2 (see 16.7.1.1).

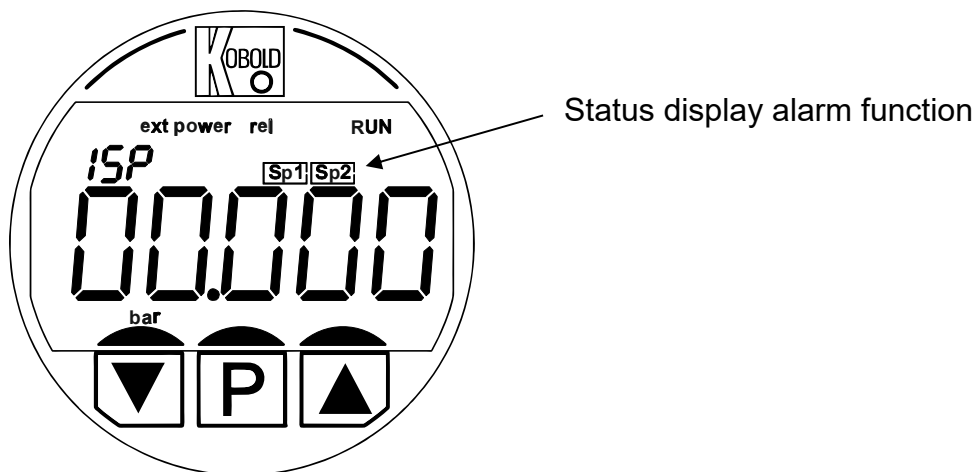

16.7.1.1 Function

The FUNC parameter defines the basic function. Limit functions and window functions are available.

Limit function (parameter LIMIT):

The switching output is active when the current measured flow value is above the switching threshold. It remains active until the measured value has fallen below the switching threshold minus the hysteresis.

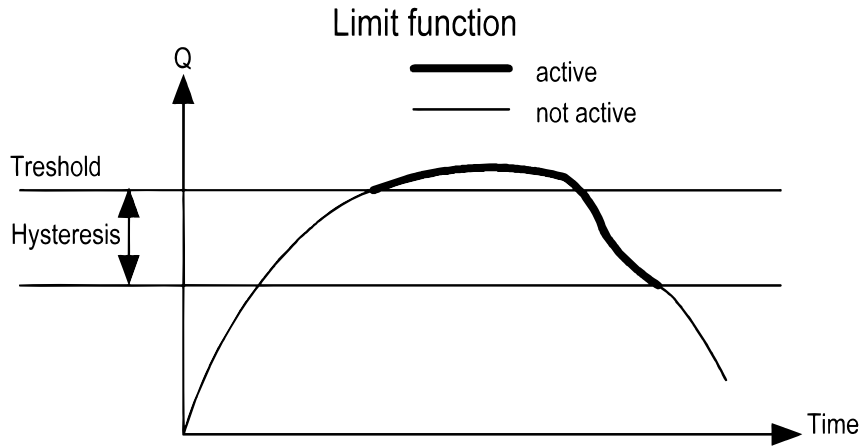

Window function (parameter WINDO):

The switching output is **active** if the current measured value is outside a window, which is formed by the "switching threshold" and the "lower threshold". The monitored window decreases in each case by the amount of the "hysteresis". If the switching output is to be **active** within the window, the parameter "switching function" must be changed from N/O to N/C.

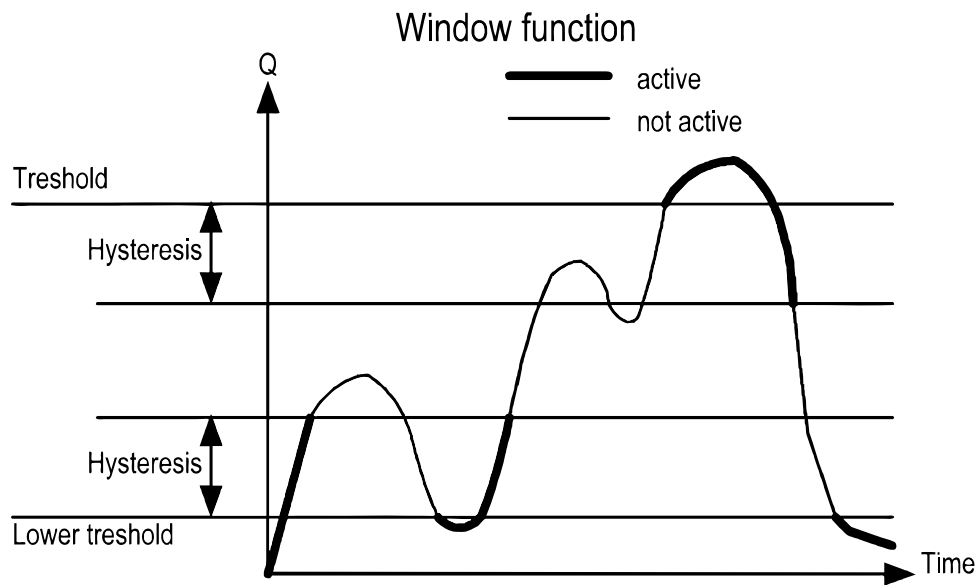

16.7.1.2 Output type (parameter TYPE)

The parameter "Output type" defines the function of the transistor output. NPN, PNP or PP (push-pull) output types are available. The push-pull type combines NPN and PNP and is therefore the best choice for most circuits. All outputs are short circuit and overload protected.

16.7.1.3 Switching threshold (parameter SWI)

The "switching function" defines the mode of operation of the outputs. In the standard setting "normally open", the output is activated (switched) when the measured value exceeds the switching threshold. This function is also known as the "normally open function", "open-circuit principle" or "N.O." (normally open). In the "Normally closed" setting, the output is already active below the switching threshold and is deactivated when the measured value exceeds the switching threshold. This function is also referred to as the "normally closed function", closed-circuit principle "or" N.C. "(normally closed).

16.7.1.4 Switching threshold (parameter THRE)

The "Switching threshold" parameter defines the limit value for the limit function and the upper limit for the window function.

16.7.1.5 Lower threshold (LTHRE parameter, only with activated window function)

The "lower switching threshold" defines the lower limit value when using the window function. This parameter remains ineffective when the limit function is used. The switching thresholds can be set both positive and negative.

16.7.1.6 Hysteresis (parameter HYST)

The appropriate setting of the "hysteresis" parameter ensures that the switching outputs do not switch on and off continuously when the current measured value fluctuates around the switching threshold. The hysteresis value should therefore always be greater than the real measured value fluctuations. As a result, a targeted suppression can be achieved.

16.7.1.7 Switching delay (SUPPR parameter)

Further interference suppression of the switching outputs from fluctuating measurement signals can be achieved by setting the SUPPR parameter. If this parameter is selected greater than 0, the switching of the output is delayed accordingly. The parameter SU DI defines whether the delay should take effect when the switching threshold is exceeded or not reached (alternatively in both directions).

"High" means that the delay is active when the measured value exceeds the switching threshold, "Down" means the corresponding effect when the value falls below the switching threshold.

The measured value must continuously exceed or fall below the switching threshold with the value of [SUPPR] before the switching output is activated.

With this function, sporadic exceeding of limit values can be safely suppressed. The response time of the output is generally extended according to the value of the SUPPR parameter.

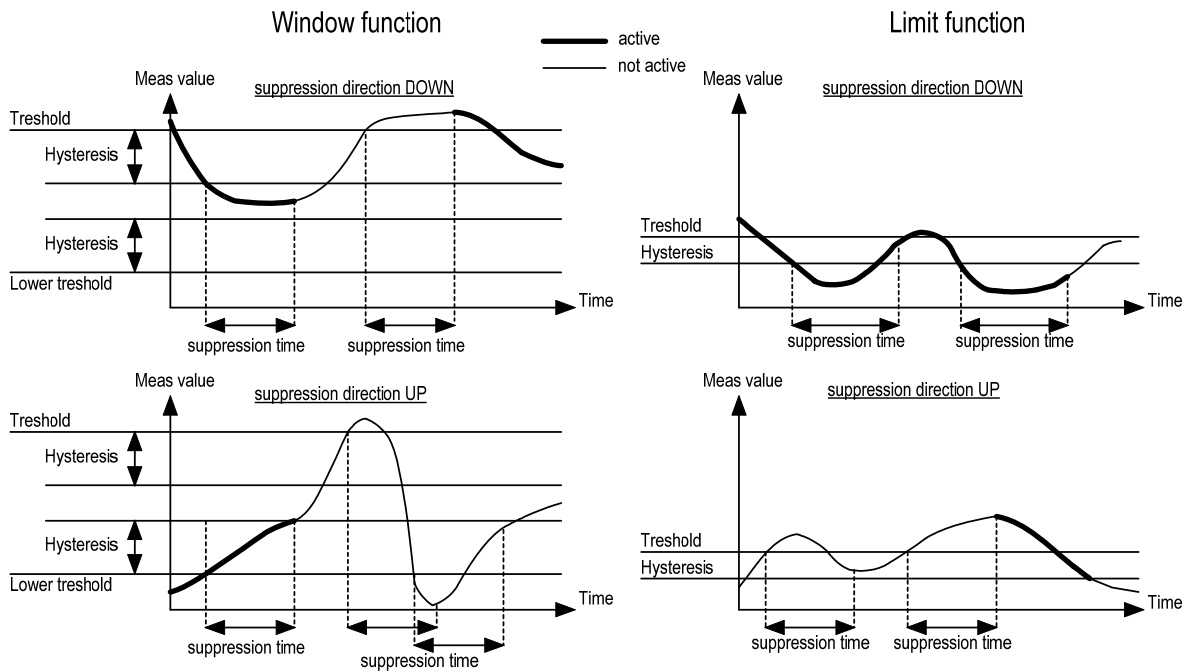

Examples of the effect of the switching delay for window and limit function

16.7.2 Analogue outputs

16.7.2.1 Current output 0-20 mA / 4-20 mA

The current output is a measurement variable (pressure, temperature or force) in scaled form as a 0-20 mA or 4-20 mA current signal.

The current output is scaled using the parameters "Value 20 mA" and "Value 0 mA" or "Value 4 mA". The "Value 20 mA" parameter is set to the value for the end of the measuring range by default, but can be parameterized anywhere within the measuring range, but this must always be greater than the start of the measuring range.

The parameters "Value 0 mA" and "Value 4 mA" define the measured values for the starting current value. These can also be freely set in the measuring range.

Note 1: If the "Value 20 mA" parameter is set smaller than the end of the measuring range, the accuracy of the output current value is reduced.

Note 2: The load for the current output must not be greater than 500 Ω.

16.7.2.2 Voltage output 0-10 V / 2-10 V

The voltage output is a measurement variable (pressure, temperature or force) in scaled form as a 0-10 V / 2-10 V voltage signal.

The voltage output is scaled using the parameters "Value 10 V" and "Value 0 V" or "Value 2 V". The "Value 10 V" parameter is set to the value for the end of the measuring range by default, but can be parameterized anywhere within the measuring range, but must always be greater than the start of the measuring range. The parameters "Value 0 V" and "Value 2 V" define the measured values for the starting voltage value. These can also be freely set in the measuring range.

Note 1: If the value is set smaller than the end of the measuring range, the accuracy of the voltage value output is reduced.

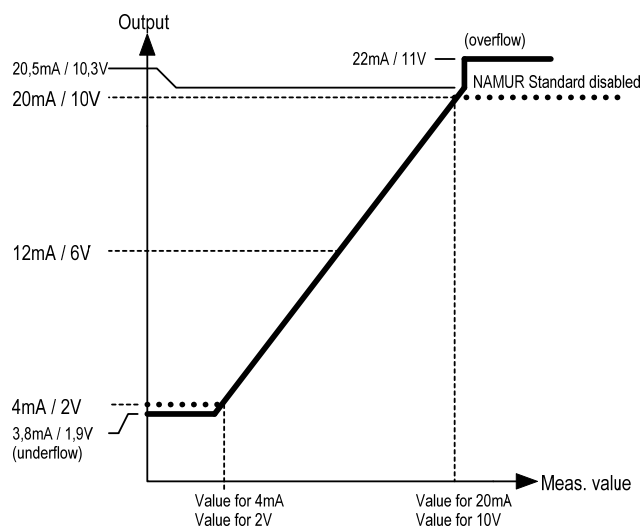

Output behavior 4-20 mA and 2-10 V

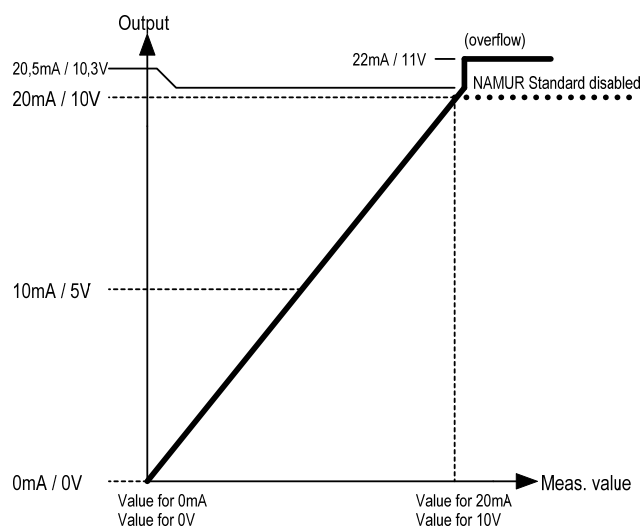

Output behaviour 0-20 mA and 0-10 V

16.7.2.3 Activation of behaviour according to NAMUR recommendation NE43

For all analogue outputs (current and voltage), the output behaviour can be activated according to NAMUR recommendation NE43. When the function is activated, e.g. the linear output of the 4 to 20 mA signals to 3.8 to 20.5 mA. Above 20.5 mA, the current value jumps to approx. 22 mA to signalise a measuring range overshoot. Current output values between 3.8 and 4.0 mA indicate that the measuring range is undershot. The output of approximately 3.6 mA signals a device or process fault.

16.7.3 Frequency output (OUT1 and OUT2)

The MAN-LC provides a scalable frequency output. If this output is activated, the measurement variable (pressure, temperature or force) assigned to the frequency output is output proportionally as a frequency with a 1: 1 pulse / pause duration. The output frequency at the end of the measuring range can be set (parameter "max. Frequency"). With the two parameters "Value at 0 Hz" and "Value at max Hz", the frequency output can be freely scaled in the measuring range.

Behavior on OVERFLOW:

If the measured value is in the overflow range, a constant frequency is output.

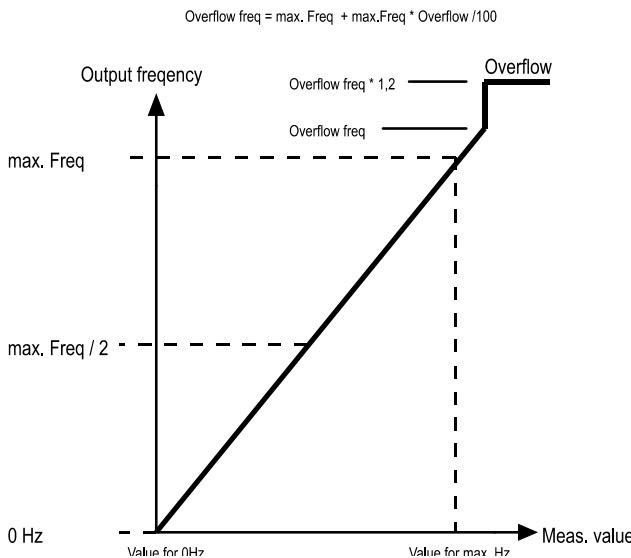

Output behavior Frequency output

16.7.4 KofiCom (parameter KOFIC, OUT1)

KofiCom is an in-house communication standard for service purposes. This function is only available for factory service.

16.7.5 IO-Link (parameter IOLIK, OUT1)

If OUT1 is set to IOLIK, the IO-Link functionality can be used via this output.

16.7.6 Control input (parameters CTLIN, OUT1)

Output 1 can be configured as a control input. This can be used to reset the MIN / MAX memory, depending on the assigned measurement variable.

If output 1 is parameterized as a control input, the saved MIN / MAX values can be reset to the current measured value with the aid of an externally applied active control signal. There is no internal pull-up resistor, so an active LOW / HIGH signal must be applied. The control input must not be left open!

HIGH threshold: $15 \text{ V}_{\text{DC}} \leq U_{\text{High}} \leq V_{\text{s}}$
 LOW threshold: $0 \leq U_{\text{Low}} \leq 10 \text{ V}_{\text{DC}} \leq$

Function	Measured value	Control pulse duration
MIN/MAX Reset	(Pressure, temperature or force)	$0.5s < t_{high} < 4s$

16.8 User service (main menu USER)

A reset function and password setting are available to the user in the user service. Together with the activation of a user password, menu access for the user can therefore be blocked by a master user.

16.8.1 User password (PASSWORD parameter)

In the factory setting, the user password is set to "00000", which means that the user functions are freely accessible. If the user password is set differently from "00000", the password query will be activated the next time you enter the user menu. If the set password is no longer known, a master password can be requested from KOBOLD.

16.8.2 Factory reset (FACTS parameter)

By activating this function, the user can reset the device to the factory settings. Any user settings will then be lost and the device will be in the delivery state again.

16.8.3 Menu lock (MLOCK parameter)

With this function the user can activate the password query when entering the menu. If the "LOCK" setting is selected, the settings menu can only be accessed by entering the password that is defined in "PASSW".

16.8.4 Simulation timeout (SAS parameter)

Specifies the time in minutes after which the simulation is automatically ended.

16.9 Factory service (main menu FACT)

Access is only intended for authorized persons and is password-protected.

16.10 Info (main menu INFO)

General (parameter GEN)

The device type is displayed in this info option

Version (parameter VER)

The firmware version of the device is displayed in this info option

Firmware revision (parameter REV)

The firmware revision of the device is displayed in this info option

17. Maintenance

If the medium to be measured is not contaminated, the device is maintenance-free.

18. Technical Data

Operating instructions, data sheet, approvals and further information via the QR code on the device or via www.kobold.com

19. Device delivery status

Device type		Parameter	Value	Comment
MAN-SC	MAN-LC			
X	X	Display layout	Single => Pressure reading	
X	X	Display refresh	1 s	
-	X	Output 1	IO-Link	
-	X	Output 2	deactivated	
X	X	Pressure measuring unit	Bar	
X	X	Force measuring unit	N	
X	X	Temperature measuring unit	°C	

20. Order codes

Operating instructions, data sheet, approvals and further information via the QR code on the device or via www.kobold.com

21. Dimensions

Operating instructions, data sheet, approvals and further information via the QR code on the device or via www.kobold.com

22. Disposal

See “General Safety Instructions” - via the QR code on the device or via www.kobold.com

23. IO-Link Process Data Structure

Process data length: 5 bytes

Byte	Bitoffset	Data	Bitcount	Format	Factor	Range	Value	Comment
0-3	10	Pressure	30	IntegerT	1/100000	-536870913 - +536870912	Bar	
3-4	2	Temperature	8	IntegerT		-128 - +127	°C	Stays at -128 °C for MAN without temperature sensor / decimal places are truncated -> min. resolution is 1 °C
4	1	Status Out 1	1	BooleanT		0/1		
4	0	Status Out 2	1	BooleanT		0/1		

Pressure																													
0	1	2	3	4	5	6	7	0	1	2	3	4	5	6	7	0	1	2	3	4	5	6	7	0	1	2	3	4	5
Byte 0								Byte 1								Byte 2								Byte 3					

Temperature																
6							7	0				1	2	3	4	5
Byte 3								Byte 4								



Status 1	Status 2
6	7
Byte 4	Byte 4

As long as a diagnostic status of type "Error" is active for the process values print, the corresponding transmitted process values are invalid. The process values are only valid when the corresponding diagnostic status is deactivated.

 <p>NOTE</p>	<p>The process data representation corresponds to the device-side data structure. Please note: Siemens IO-Link masters operate with reversed high and low byte assignments when addressing bytes!</p>
Note	

24. IO-Link manufacturer's declaration

24.1 MAN-LC Device-ID 196864

 IO-Link	
<p>MANUFACTURER'S DECLARATION OF CONFORMITY</p>	
<p>We: Kobold Messring GmbH Nordring 22-24 65719 Hofheim Germany</p>	
<p>declare under our own responsibility that the product(s):</p>	
<p>MAN-LC***** (IO-Link Device)</p>	
<p>to which this declaration refers conform to:</p>	
<input checked="" type="checkbox"/>	<ul style="list-style-type: none"> • IO-Link Interface and System Specification, V1.1, July 2013 (NOTE 1,2) • IO Device Description, V1.1, August 2011
<input checked="" type="checkbox"/>	<ul style="list-style-type: none"> • IO-Link Interface and System Specification, V1.0, January 2009 (NOTE 1) • IO Device Description, V1.0.1, March 2010 •
<p>The conformity tests are documented in the test report: <i>IO-Link_Device_TestReport_MAN-LC_20190704.pdf</i></p>	
<p>Issued at Hofheim, 01.06.2020</p>	
<p>Harald Peters <i>General Manager</i></p>	<p>Manfred Wenzel <i>Proxy Holder</i></p>
<p>Reproduction and all distribution without written authorization prohibited</p>	

NOTE 1 Relevant Test specification is V1.1, July 2014

NOTE 2 Additional validity in Corrigendum Package 2015

24.1 IO-Link Herstellererklärung für Device-ID 196865

Die IO-Link Herstellererklärung steht unter folgenden Link zur Verfügung:
<https://ioddfinder.io-link.com/productvariants/search/45601>

24.2 IO-Link Herstellererklärung für Device-ID 196866

Die IO-Link Herstellererklärung steht unter folgenden Link zur Verfügung:
<https://ioddfinder.io-link.com/productvariants/search/45602>

25. EU Declaration of Conformity

We, KOBOLD Messring GmbH, Nordring 22-24, 65719 Hofheim, Germany, declare under our sole responsibility that the product:

Digital Pressure Gauge

Model: MAN-SC/-LC

to which this declaration relates is in conformity with the following EU directives stated below:

2014/30/EU

EMC Directive

2011/65/EU

RoHS (category 9)

2015/863/EU

Delegated Directive (RoHS III)

Only for MAN-SC:

2006/66/EG

Directive Batteries and Accumulators

Also, the following standards are fulfilled:

EN IEC 61326-1:2021

Electrical equipment for measurement, control and laboratory use - EMC requirements - Part 1: General requirements, Industrial area (measurement of immunity to RF fields up to 2.7 GHz)

EN IEC 63000:2018 Technical documentation for the assessment of electrical and electronic products with respect to the restriction of hazardous substances

Hofheim, 10 October 2023



H. Volz
General Manager

J. Burke
Compliance Manager

26. UK Declaration of Conformity

We, KOBOLD Messring GmbH, Nordring 22-24, 65719 Hofheim, Germany, declare under our sole responsibility that the product:

Digital Pressure Gauge

Model: MAN-SC/-LC

to which this declaration relates is in conformity with the following UK directives stated below:

S.I. 2016/1091 Electromagnetic Compatibility Regulations 2016
S.I. 2012/3032 The Restriction of the Use of Certain Hazardous Substances
in Electrical and Electronic Equipment Regulations 2012

Only for MAN-SC:

S.I. 2009/890 Waste Batteries and Accumulators Regulations 2009

Also, the following standards are fulfilled:

BS EN IEC 61326-1:2021

Electrical equipment for measurement, control and laboratory use. EMC requirements. General requirements, Industrial area (measurement of immunity to RF fields up to 2.7 GHz)

BS EN IEC 63000:2018

Technical documentation for the assessment of electrical and electronic products with respect to the restriction of hazardous substances.

Hofheim, 10 October 2023



H. Volz
General Manager



J. Burke
Compliance Manager